

Linear Diaphragm Pumps AP-50G, AP-60G, AP-80H, AP-100, AP-120

Flow at rated pressure

47 to 125 l/min at 200 mbar

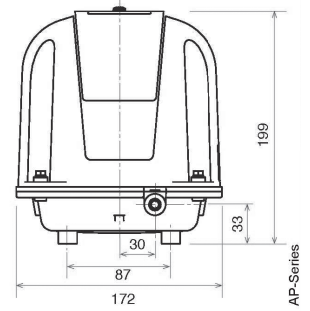
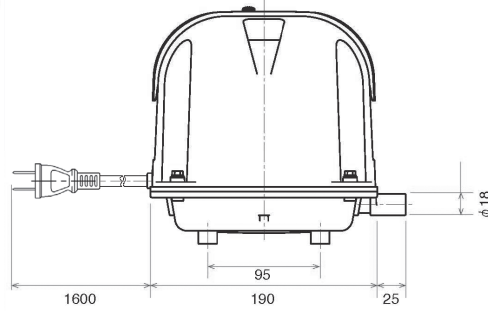

AP-Series

PNEUMATIC DATA

Description	AP-50G	AP-60G	AP-80H	AP-100	AP-120
Part number	52500001	52500002	52500480	52500472	52500473
Flow at rated pressure	47 l/min	60 l/min	82 l/min	108 l/min	125 l/min
Rated pressure	200 mbar	200 mbar	200 mbar	200 mbar	200 mbar
Operating range	100 to 300 mbar	100 to 300 mbar	100 to 300 mbar	140 to 300 mbar	160 to 300 mbar

ELECTRICAL DATA

Motor type	Linear drive	Linear drive	Linear drive	Linear drive	Linear drive
Nominal Voltage	230V 50Hz	230V 50Hz	230V 50Hz	230V 50Hz	230V 50Hz
Consumption at rated pressure	0.29 A / 31 W	0.39 A / 41 W	0.8 A / 73 W	1.06 A / 99 W	1.45 A / 128 W
Efficiency at rated pressure	0.66 W/l	0.68 W/l	0.89 W/l	0.92 W/l	1.02 W/l

GENERAL DATA

Ambient temperature	-10 to 40 °C	-10 to 40 °C	-10 to 40 °C	-10 to 40 °C	-10 to 40 °C
Weight	5.8 kg	5.8 kg	6.1 kg	6.1 kg	6.1 kg
Outlet diameter	18 mm	18 mm	18 mm	18 mm	18 mm
Average sound level	34 dB (A)	34 dB (A)	35 dB (A)	37 dB (A)	38 dB (A)

SERVICE PARTS

Air filter and gasket kit	700582Y	700582Y	700582Y	700582Y	700582Y
Air filter kit	700583Y	700583Y	700583Y	700583Y	700583Y
*Maintenance Rebuild Kit	700608	700608	700579	700579	700579

All listed values are measured at standard atmospheric conditions.

If 230V 60Hz is required, please consult factory

*Maintenance Rebuild Kit denotes part is only available for trained service personnel. Contact your local sales representative.

FLOW CURVES

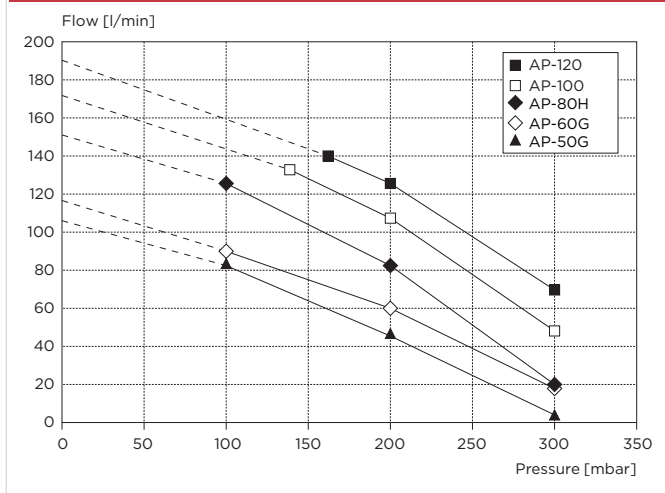

Note: Operation outside specified operating range is not recommended.
All listed values are measured at standard atmospheric conditions

SERVICE PARTS

*Maintenance rebuild kit consists of:
2 x Pump head with valves
2 x Diaphragm assembly
2 x Diaphragm gasket
2 x Diaphragm nut
2 x Diaphragm washer
1 x Air cleaner element
1 x Air cleaner gasket
1 x Cover plate gasket

Air filter and gasket kit consists of:
1 x Air cleaner element
1 x Air cleaner gasket
1 x Cover plate gasket
1 x Noise absorbing net
1 x Tank gasket

Air filter kit consists of:
5 x Air cleaner element
5 x Air cleaner gasket

SUPPLIED AS STANDARD

Cable/Euro-plug
Air connector, consists of:
(part number 700073)
1 x Angled outlet hose 170/50mm
2 x Hose clamp

5250... Stock program