

JetFlex® HD 340 Disc Diffuser

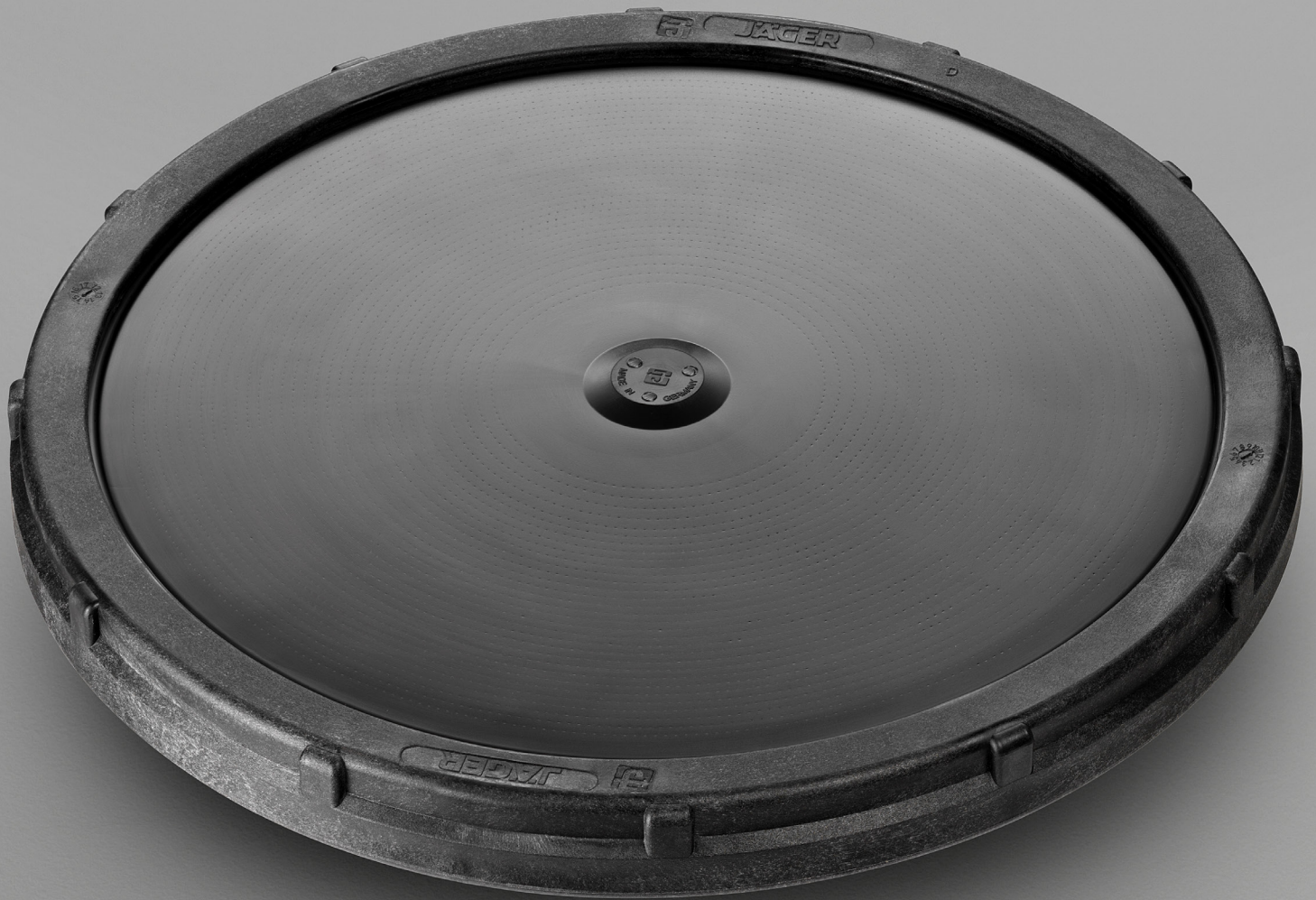



Dimensions

Diameter total [A] / effective	Installation height above pipe [B]	Overall height [C]	Orifice	Thread
346/295 mm	46 mm	76 mm	10 mm	R 3/4" +1"

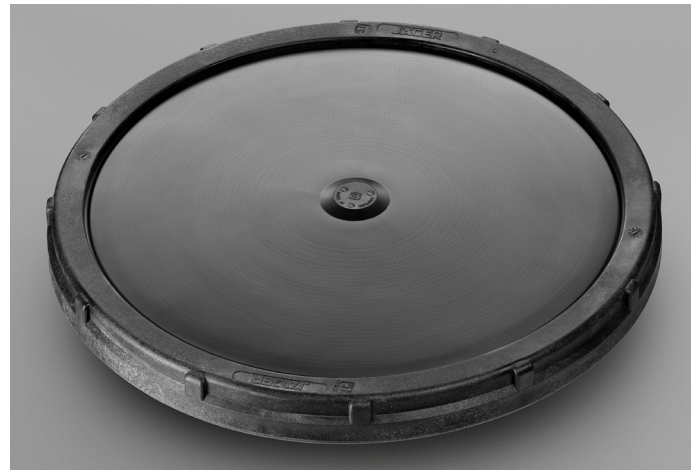

Installation drawing

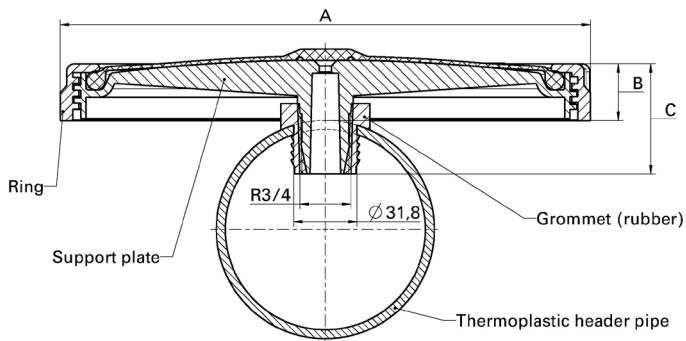

A = 346 mm
B = 46 mm
C = 76 mm

SSOTE and headloss for HD 340 F053A

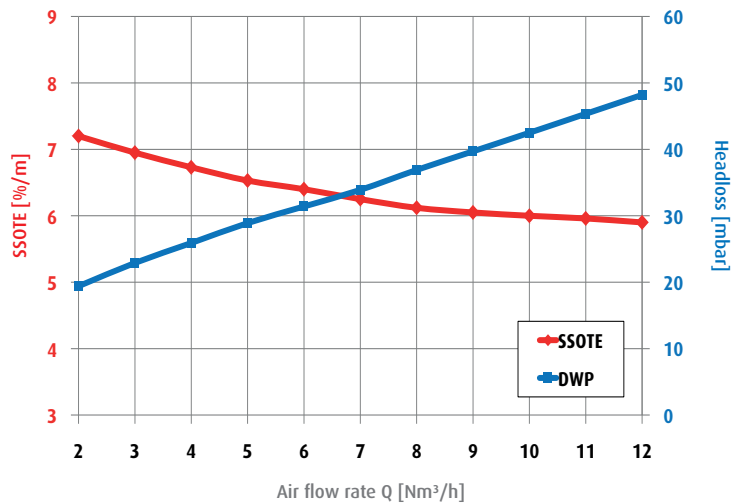

Perforated area	Air flow rate at standard operating conditions	Max. overload / maintenance air flow rate	Operating mode
0.060 m ²	2 - 12 Nm ³ /h	15 Nm ³ /h	continuous / intermittent

Connectors to plastic header pipe

	Colour	Permitted wall thickness of header tube	Diameter of straightdrilled hole	Material
Rubber saddle	black	4 - 8 mm	32 +0/-0,5 mm	EPDM 75 ± 5 Shore A
PVC saddle 90 + 110 mm	grey/white	2 mm	36 ± 0,5 mm	PVC
Clamp adapter 90 + 110 + 114,3 mm	black	2 mm	multiple	PP20%GF/SI/VA

Please see our operation manuals for more details.



Membrane materials

Material	Techn. standard	EPDM F053A	EPDM F057A	Techn. standard	Silicone
Colour		black	black		green
Plasticiser (%)		28	9		0
Density (g/cm ³)	DIN EN ISO 1183-1	1.07	1.06	DIN EN ISO 1183-1	1.17
Tensile strength (N/mm ²)	DIN 53504	>10	>8	DIN 53504	>10
Elongation at break (%)	DIN 53504	>450	>300	DIN 53504	>610
Tear strength (N/mm)	DIN EN ISO 34-1 (method A)	>6	>3	ASTM D624B	>51
Hardness (Shore A)	DIN ISO 7619	52 ± 5	60 ± 5	DIN ISO 7619	60 ± 5
Operating air temperature (°C)		5 - 80	5 - 80		5 - 100
Operating water temperature (°C)		5 - 40	5 - 40		5 - 40

Support plates

Material	Colour
PP 30% GF	black

Accessories

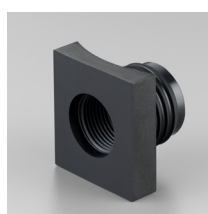
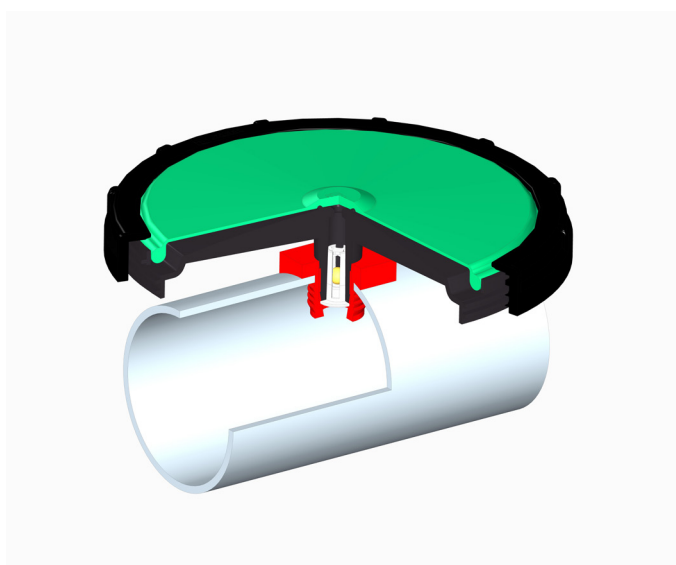

Rubber saddle



PVC saddle

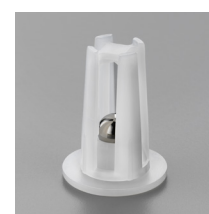

Check valve



Clamp adapter with female thread



Clamp adapter without thread

Please see our accessories catalogue for more details.