

# JetFlex® HD 200 Disc Diffuser





## Dimensions

Diameter total [A] / effective	Installation height above pipe [B]	Overall height [C]	Orifice	Thread
233/184 mm	30 mm	60 mm	6 mm	R 3/4"



## Installation drawing

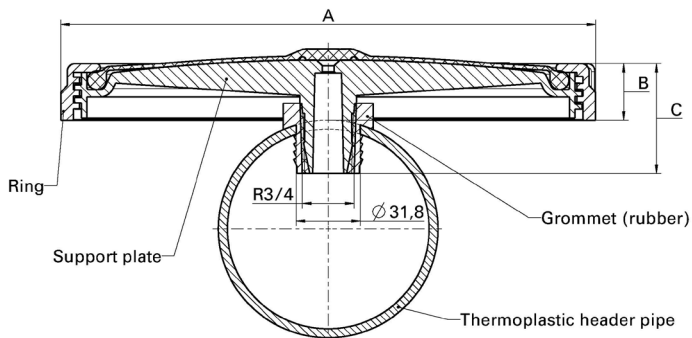

A = 233 mm  
B = 30 mm  
C = 60 mm

## SSOTE and headloss for HD 200 F053A

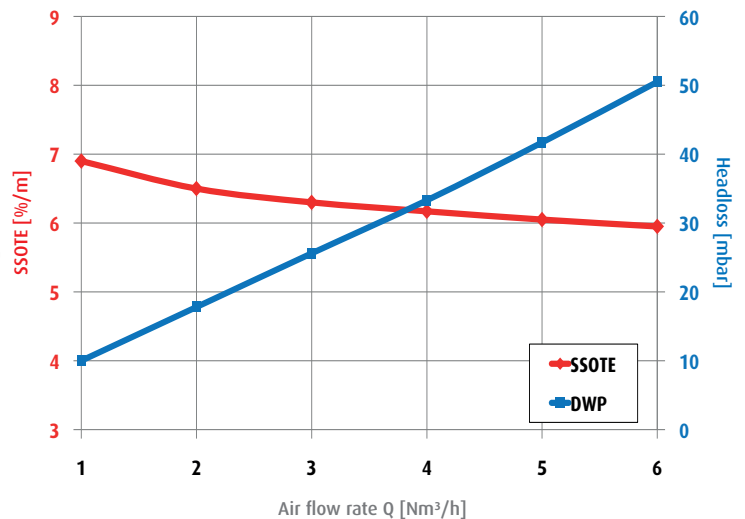

Perforated area	Air flow rate at standard operating conditions	Max. overload / maintenance air flow rate	Operating mode
0.025 m <sup>2</sup>	1 - 6 Nm <sup>3</sup> /h	8 Nm <sup>3</sup> /h	continuous / intermittent

## Connectors to plastic header pipe

	Colour	Permitted wall thickness of header tube	Diameter of straightdrilled hole	Material
Rubber saddle	black	4 - 8 mm	32 +0/-0,5 mm	EPDM 75 ± 5 Shore A
PVC saddle 90 + 110 mm	grey/white	2 mm	36 ± 0,5 mm	PVC
Clamp adapter 90 + 110 + 114,3 mm	black	2 mm	multiple	PP 20 % GF / SI / VA

Please see our operation manuals for more details.



## Membrane materials

Material	Techn. standard	EPDM F053A	EPDM F057A	Techn. standard	Silicone
Colour		black	black		green
Plasticiser (%)		28	9		0
Density (g/cm <sup>3</sup> )	DIN EN ISO 1183-1	1.07	1.06	DIN EN ISO 1183-1	1.17
Tensile strength (N/mm <sup>2</sup> )	DIN 53504	>10	>8	DIN 53504	>9
Elongation at break (%)	DIN 53504	>450	>300	DIN 53504	>510
Tear strength (N/mm)	DIN EN ISO 34-1 (method A)	>6	>3	DIN EN ISO 34-1 (method B)	>36
Hardness (Shore A)	DIN ISO 7619	52 ± 5	60 ± 5	DIN 53505	60 ± 5
Operating air temperature (°C)		5 - 80	5 - 80		5 - 100
Operating water temperature (°C)		5 - 40	5 - 40		5 - 40

## Support plates

Material	Colour
PP 30% GF	black

## Accessories

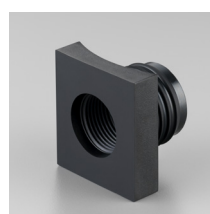
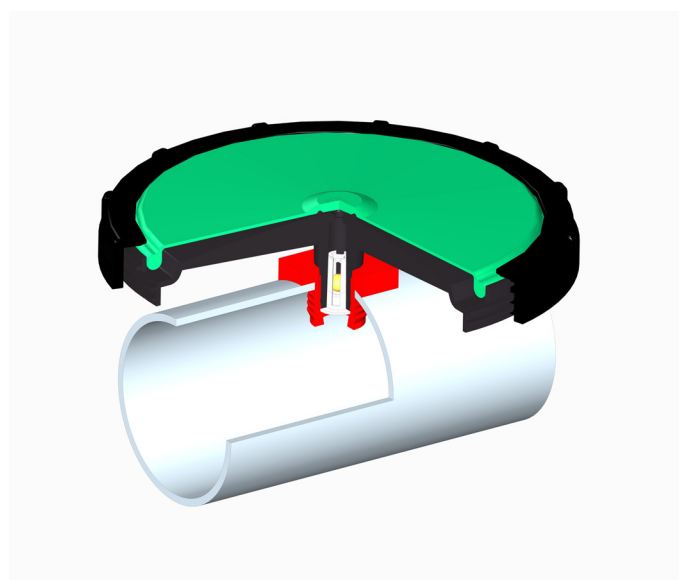

Rubber saddle



PVC saddle



Check valve



Clamp adapter with female thread



Clamp adapter without thread

Please see our accessories catalogue for more details.